

Low-cost drives can be an expensive alternative

Application Note

When it comes time to replace old electro-mechanical motor starters the new low-horsepower, variable speed drives (VSDs) look like an attractive solution. After all, drives offer many advantages over motor starters. They don't create inrush current. They don't generate switching transients. They have high displacement power factors. And, they're less expensive. In fact, we can anticipate the day when solid-state drives replace many if not most mechanical starters such as programmable logic controllers (PLCs) replaced mechanical relay-based control.

But beware, low-horsepower drives, especially the lower cost models, can have hidden potential costs and downtime risks.

One development in drive design that has been startling is the reduced size of newer drives. Somehow engineers have been able to cram more horsepower into smaller, more compact packages, to the point that low-horsepower drives now have more or less the same footprint as mechanical starters.

Historically a major impediment in building smaller drives was the need to dissipate heat. A drive first converts sine wave ac into dc, then stores the dc in capacitor banks (in a section referred to as the dc link). The inverter then switches the dc to create a pulse width modulated (PWM) signal – a kind of

synthetic ac. That process was a prime generator of heat. But in newer drives the switching is done by a semiconductor device called the insulated gate bipolar transistor (IGBT). IGBTs have been developed to carry more and more current, but of more relevance in this context, the switching speed of IGBTs has become faster and faster (100-200 ns or so). The faster a switch, the more efficient it is (an ideal switch would go

from off to on in zero seconds). Why? A switch that is off or on is not consuming energy (ignoring the very small voltage drop across any semiconductor). A switch is only wasting energy; i.e., generating heat, in the transition stage from off to on and vice versa. Higher switching speeds result in less heat loss and increased efficiency. The result is smaller heat sinks and fans, and more compact drives.



Advantages

In addition to energy savings, drives offer many other benefits which contribute to the stability and robustness of the electrical distribution system.

- Drives do not have inrush currents (they are typically limited to 110 percent of rated current). The inrush currents associated with starting motors across-the-line can cause nuisance tripping of the motor. They can also cause voltage sags that disturb other loads. Drives will instead “soft-start” motors, typically ramping a motor and load up to speed in about 20-30 seconds.
- Drives have high displacement power factor, eliminating the need for power factor correction capacitors.
- Drives isolate the switching transients (spikes) caused when a motor is turned off. Drives will typically ramp down a motor over 20-30 seconds. When the drive finally turns off, the motor is at low-speed and low-current, producing a relatively small spike that is easily absorbed within the dc link section of the drive itself.
- Drives have programmable motor control, protection and even communication functions, far beyond what is provided by the contactor, trip unit and auxiliary contacts of the mechanical starter. For example, drives can be programmed to reverse motor rotation, eliminating the need for an additional contactor.
- On single-phase systems, drives allow the replacement of single-phase motors with more rugged three-phase motors. This is because the VSD can accept a single-phase line-side voltage and output a three-phase signal on the load (motor) side; in other words, they “transform” single-phase to three-phase voltage.

However, drives have negative as well as positive impacts on the distribution system and on the motor itself. The issues, such as harmonics and motor-drive compatibility, are essentially the same for smaller drives as for large drives. The difference is that smaller drives and motors are not as likely to get the attention that large, more expensive drives receive. The larger the VSD, the more the harmonics. A 250 hp drive, for example, is almost sure to get engineering attention to mitigate its harmonics. A 5 hp drive or smaller frequently merits little if any attention. Given the economics and impact on operations, this often makes perfect sense. But there are other times when a careful analysis of smaller horsepower drives is warranted.

Disadvantages

On single-phase systems, drives will generate 3rd and, to a lesser degree, 5th harmonics. In commercial buildings, on four-wire systems (three phases + neutral), they will contribute to the 3rd harmonic current adding up in a shared neutral; a good reason for installing neutral cables that are double the size of feeder cables. So as small drives add their contribution to the total harmonic load, any line measurements made require a true-rms meter for accuracy, particularly for current measurements. In the presence of harmonics average responding current meters can provide readings that are off by as much as 40 percent.

On three-phase systems, the 5th will be the predominant drive-generated harmonic. The 5th harmonic is a negative sequence harmonic: it creates reverse torque that will tend to make motors turn backwards. The 5th harmonic will not affect the drive’s own motor, or other motors with drive control, but it will affect motors with across-the-line mechanical starters. The across-the-line motor, driven by the much larger fundamental current, will still

turn forward, but the 5th will cause additional heating, and over time can be extremely damaging to the stator insulation. If a drive shares a bus with an across-the-line motor (such as in a motor control center), it could cause damage to the motor. Note that this 5th harmonic will probably have virtually no effect on the upstream distribution system (i.e., will cause minimal voltage distortion upstream), because its harmonic current is such a negligible portion of the total. But at the local level, where source impedance is at its highest, a bank of low-horsepower drives can cause enough voltage distortion at the local point of common coupling (PCC) to affect the motor loads which share that PCC.

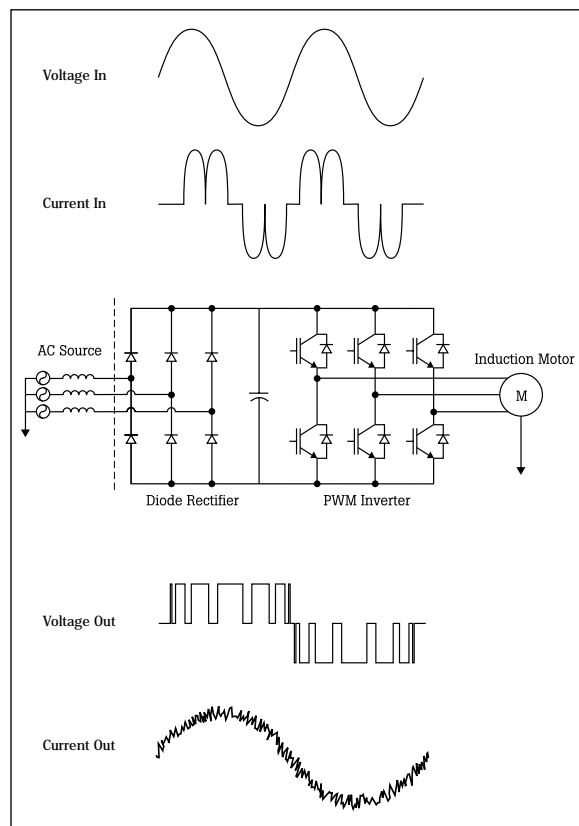

A three-phase VSD draws non-linear current which injects harmonics into the power system.

The first line of defense against harmonics should be in the drive itself. A reactor coil, sometimes called a link inductor, is integrated into the dc link of many drives. This coil tends to reduce current distortion on the line side of the drive. It will also protect the drive from transient overvoltages (notably capacitor switching transients) that can travel onto the dc link and cause dc overvoltage trips.

In some lower-cost drives, the manufacturers have cut costs by eliminating the reactor coil, making the drive a "harmonics generator." This is especially critical when it is installed on a bus with an across-the-line motor. In this instance the situation can be corrected by installing input line reactors or isolation transformers.

Buying a drive with a link inductor is no guarantee against problems, though. A similar harmonics problem occurs when a large number of small drives are installed on a bus and cumulatively they create enough harmonic distortion to trigger problems. In this instance it may not make sense to install a passive filter tuned to trap the 5th and 7th harmonics as would be typically done with a large horsepower drive. The reason is that the small loads can be highly dynamic, with constantly varying loads that a single passive filter won't mitigate. In such cases, active harmonic filters can be used. These devices track the harmonic currents and generate an out-of-phase counter current of the same harmonic and same amplitude to cancel the original harmonic. They are especially effective for dynamic loads with constantly varying harmonic currents.

Motor compatibility

VSDs can also have motor compatibility problems, especially when retrofitting drives to older motors. The high-speed switching of the IGBT in conjunction with long cable runs can cause overvoltage reflections (also known as standing-wave voltages or peak-to-peak or corona voltages) with peak voltages two to three times the dc link voltage. Many drive manufacturers will specify cable runs to not exceed 100 feet, but sometimes even this is too long. They tend to puncture insulation on the first few windings of the motor, causing premature failure of stator insulation. This is a problem common to high- and low-horsepower drives with PWM outputs. But lower-cost, lower-horsepower motors are especially vulnerable; their stator windings are often random-wound, a less costly manufacturing process, but one which means that adjacent wires could have a high potential between them, making them that much more vulnerable to overvoltage reflections. At one time, the common solution was to place low-pass filters – typically at the drive output – to reduce the overvoltages. However, in recent years inverter duty motors have been designed with voltage ratings of 1500 V, specifically to withstand overvoltage reflections (inverter duty motors are specified in NEMA MG-1, Section IV, Part 31). Many drive manufacturers now require that these motors be used with their drives.

If you have a situation involving VSDs that may be generating harmonics, the first thing to do is take measurements at key points in the

distribution system to determine what level of harmonics is present. Measurements of harmonic distortion of waveforms as well as of individual harmonics can be made easily with handheld instruments like the Fluke 43B Power Quality Analyzer. Overvoltage waveforms can be seen with a ScopeMeter® test tool or with the scope function of the Fluke 43B.

Summary

Low-horsepower ac drives are becoming more common as replacements for electro-mechanical starters. Like their high-horsepower cousins, they offer many advantages over the traditional technology. However, they also come with the same application and measurement issues as larger drives, such as harmonics and overvoltage reflections.

Fluke. *Keeping your world up and running.*

Fluke Corporation
PO Box 9090, Everett, WA USA 98206

Fluke Europe B.V.
PO Box 1186, 5602 BD
Eindhoven, The Netherlands

For more information call:
In the U.S.A. (800) 443-5853 or
Fax (425) 446-5116
In Europe/M-East/Africa (31 40) 2 675 200 or
Fax (31 40) 2 675 222
In Canada (800)-36-FLUKE or
Fax (905) 890-6866
From other countries +1 (425) 446-5500 or
Fax +1 (425) 446-5116
Web access: <http://www.fluke.com/>