

Non-Contact Infrared Thermometers

8838-8839 series

Operation Manual



TABLE OF CONTENTS

INTRODUCTION.....	3
FEATURES.....	3
WIDE RANGE APPLICATION	4
1 SAFETY.....	4
2.DISTANCE & SPOT SIZE.....	5
3 SPECIFICATIONS.....	6
4 FRONT PANEL DESCRIPTION.....	7
5 INDICATOR.....	7
6 BUTTONS.....	8
7 MEASURMENT PERATION.....	10
8 BATTERY PLACEMENT.....	11
9 NOTES.....	12
10 MAINTENANCE & CLEARING.....	14

INTRODUCTION

Thank you for purchase of the 8838/8839 Series IR Thermometer. The 8838/8839 Series is capable of non-contact (infrared) temperature measurements at the touch of a button. The built-in laser pointer increases target accuracy while the backlight LCD and handy push-buttons combine for convenient, ergonomic operation.

The Non-contact Infrared Thermometers can be used to measure the temperature of objects' surface that is improper to be measured by traditional (contact) thermometer (such as moving object, the surface with electricity current or the objects which are uneasy to be touched.)

Proper use and care of this meter will provide years of reliable service.

FEATURES:

- Precise non-contact measurements
- High distance to target ratio measures smaller surface areas at greater distances
- Widest temperature range
- Unique flat surface, modern housing design
- Built-in laser pointer
- Automatic Data Hold
- °C/°F switch
- Emissivity digitally adjustable from 0.10 to 1.0
- MAX,MIN,DIF, AVG temperature displays
- Backlight LCD display
- Built-in laser pointer
- Automatic selection range and Display Resolution 0.1°C(0.1°F)
- Trigger lock
- Set high and low alarms

WIDE RANGE APPLICATION:

Food preparation, Safety and Fire inspectors, Plastic molding, Asphalt, Marine and Screen printing, measure ink and Dryer temperature, HVAC/R, Diesel and Fleet maintenance.

1. SAFETY

- Use extreme caution when the laser beam is turned on.
- Do not let the beam enter your eye, another person's eye or the eye of an animal.
- Be careful no to let the beam on a reflective surface strike your eye.
- Do not allow the laser light beam impinge on any gas which can explode.



2 Distance & Spot Size

As the distance (D) from the object increases, the spot size (S) of the area measured by the unit becomes larger. The relationship between distance and spot size for each unit is listed below. The focal point for each unit is 914mm (36"). The spot sizes indicate 90% encircled energy.

Fig: 1

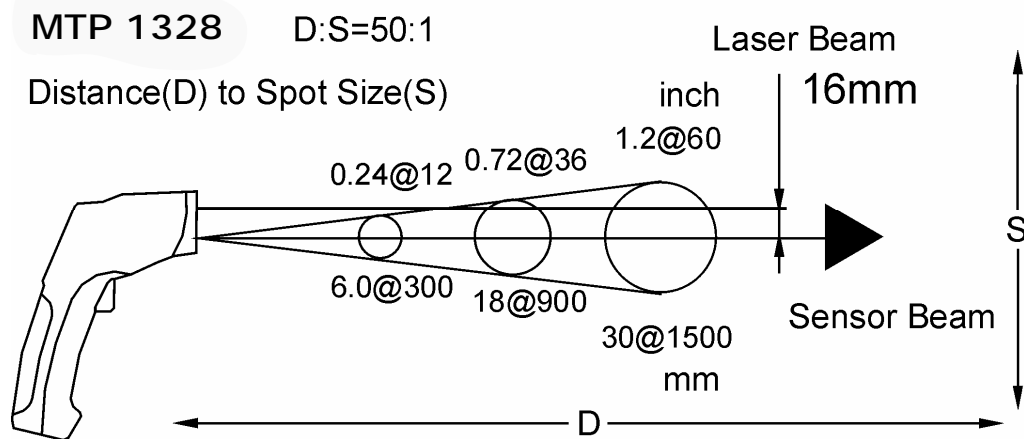

3.SPECIFICATIONS

Model	Temperature range	D: S
ST-8838	-50 to 1000°C(-58 to 1832°F)	30:1
ST-8839	-50 to 1000°C(-58 to 1832°F)	50:1
Display resolution	0.1°C(0.1°F)	
Accuracy	for targets:	
Assumes ambient operating temperature of 23 to 25°C(73 to 77°F)		
-50 to -20°C(-58 to -4°F):	±5°C(±9°F)	
-20 to 200°C(-4 to 392°F):	± 1.5% of reading ± 2°C(±3.6°F);	
200 to 538°C (392 to 1000°F):	± 2.0% of reading ±2°C(±3.6°F);	
538 to 1000°C(1000 to 1832°F):	± 3.5% of reading ± 5°C(±9°F)	
Response time	Less than 1 second	
Spectral response	8~14um	
Emissivity	Digitally adjustable from 0.10 to 1.0	
Over range indication	LCD will show “-0L”,”0L”	
Polarity	Automatic (no indication for positive polarity); Minus (-) sign for negative polarity	
Diode laser	Output <1mW,Wavelength 630~670nm, Class 2(II) laser product	
Operating temp.	0 to 50°C(32 to 122°F)	
Storage temp.	-20 to 60°C (-4 to 140°F)	
Relative humidity	10%~90%RH operating, <80%RH storage	
Power supply	9V battery, NEDA 1604A or IEC 6LR61, or equivalent	
Weight	290g (10.2 oz.)	
Size	100 x 56 x 230mm (3.9 x 2.2 x 9.0”)	
Safety	“ CE ” Comply with EMC	

Note:

- **Accuracy:** Given at 18 to 28°C (64 to 82 °F), less than 80 % RH.
- **Field of View:** Make sure that the target is larger than the unit's spot size. The smaller the target, the closer you should be to it. When accuracy is critical, make sure the target is at least twice as large as the spot size.

4.FRONT PANEL DESCRIPTION

- ① IR sensor
- ② Laser pointer beam
- ③ LCD Display
- ④ Down button
- ⑤ Up button
- ⑥ Mode button
- ⑦ Laser/Backlight button
- ⑧ Measurement Trigger
- ⑨ Handle Grip
- ⑩ Battery Cover

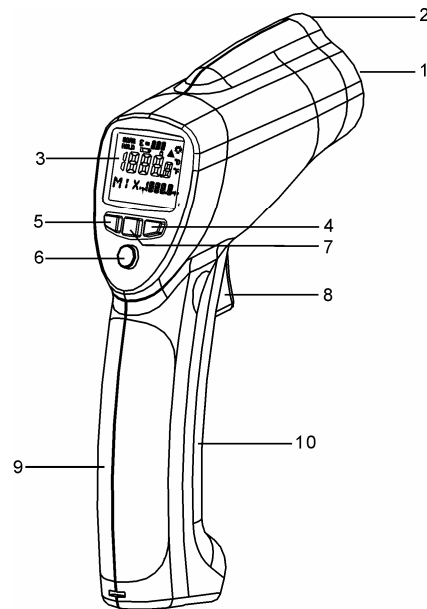

5.INDICATOR

- ① Data hold
- ② Measuring indication
- ③ Emissivity symbol and value
- ④ Low battery, lock and laser "ON" symbols
- ⑤ Backlight "ON" symbol
- ⑥ °C/°F symbol
- ⑦ High alarm and low alarm symbol
- ⑧ Temperature values for the MAX, MIN, DIF, AVG HAL and LAL.
- ⑨ Symbols for EMS, MAX, MIN, DIF, AVG, HAL and LAL.
- ⑩ Current temperature value

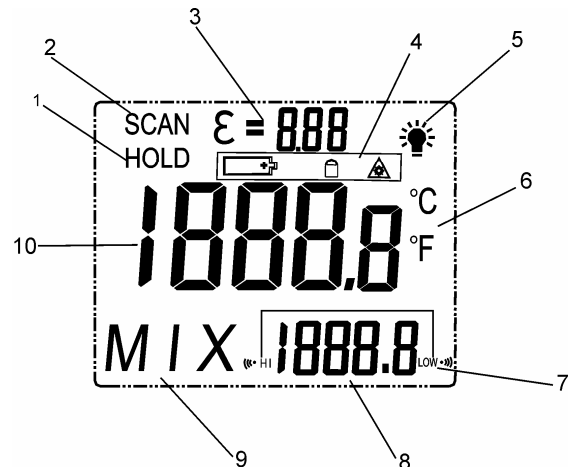

6.BUTTONS

- ① Up button (for EMS,HAL,LAL)
- ② MODE button
- ③ Down button (for EMS,HAL,LAL)
- ④ Laser/Backlight ON/OFF button
(pull trigger and press button to activate laser/backlight)

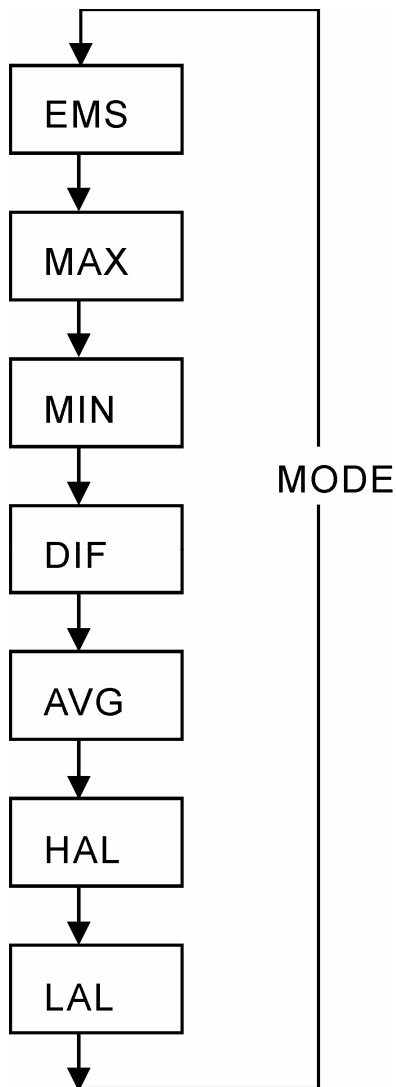
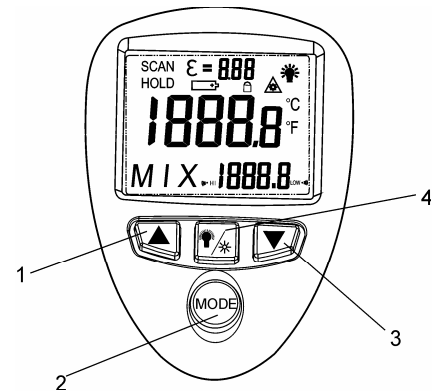

MODE Button Function

The infrared thermometer measures Maximum (MAX), Minimum (MIN), Differential (DIF), and Average (AVG) Temp. Each time you take a reading. This data is stored and can be recalled with the MODE button until a new measurement is taken. When the trigger is pulled again, the unit will begin measuring in the last mode selected.

Pressing the MODE button also allows you to access the High Alarm(HAL),Low Alarm(LAL), Emissivity(EMS).Each time you press MODE ,you advance through the mode cycle. The diagram shows the sequence of functions in the MODE cycle.

Switching °C/°F, LOCK ON/OFF and SET ALARM.

- ① °C/°F
- ② LOCK ON/OFF
- ③ SET ALARM

Select the temperature units (°C or °F) using the °C/°F switch

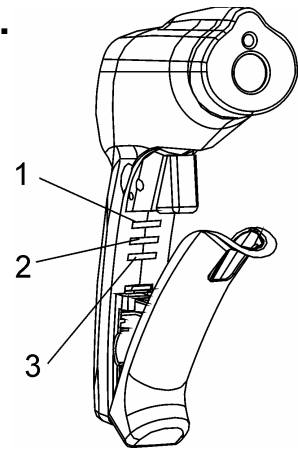

To lock the unit on for continuous measurement, slide the middle switch **LOCK ON/OFF** right. If the trigger is pulled while the unit is lock on, the laser and backlight will turn on if they have been activated. When the unit is locked on, the backlight and laser will remain on unless it is turned off using the **Laser/Backlight** button on the keypad.

To activate the alarms, please slide the bottom switch **SET ALARM** right.

To set values for the High Alarm (**HAL**), Low Alarm (**LAL**) and Emissivity (**EMS**), firstly active the display by pulling the trigger or press the **MODE** button, then press the **MODE** button until the appropriate code appears in the lower left corner of the display, press the **UP** and **DOWN** buttons to adjust the desired values.

7.MEASUREMENT OPERATION

- ① Hold the meter by its **Handle Grip** and point it toward the surface to be measured.
- ② Pull and hold the **Trigger** to turn the meter on and begin testing. The display will light if the battery is good. Replace the battery if the display does not light.
- ③ While measuring, the SCAN display icon will appear in the upper left hand corner of the LCD.
- ④ Release the Trigger and the HOLD display icon will appear on the LCD indicating that the reading is being held.
- ⑤ The meter will automatically power down after approximately 7 seconds after the trigger is released.(Unless the unit is locked on)

Note: Measurement considerations

Holding the meter by its handle, point the IR Sensor toward the object whose temperature is to be measured. The meter automatically compensates for temperature deviations from ambient temperature. Keep in mind that it will take up to 30 minutes to adjust to wide ambient temperatures are to be measured followed by high temperature measurements, some time (several minutes) is required after the low (and before the high) temperature measurements are made.

This is a result of the cooling process, which must take place for the IR sensor.

8. BATTERY REPLACEMENT

- ① As battery power is not sufficient, LCD will display “” replacement with one new battery type 9V is required.
- ② Open battery cover, then take out the battery from instrument and replace with a new 9-Volt battery and place the battery cover back.

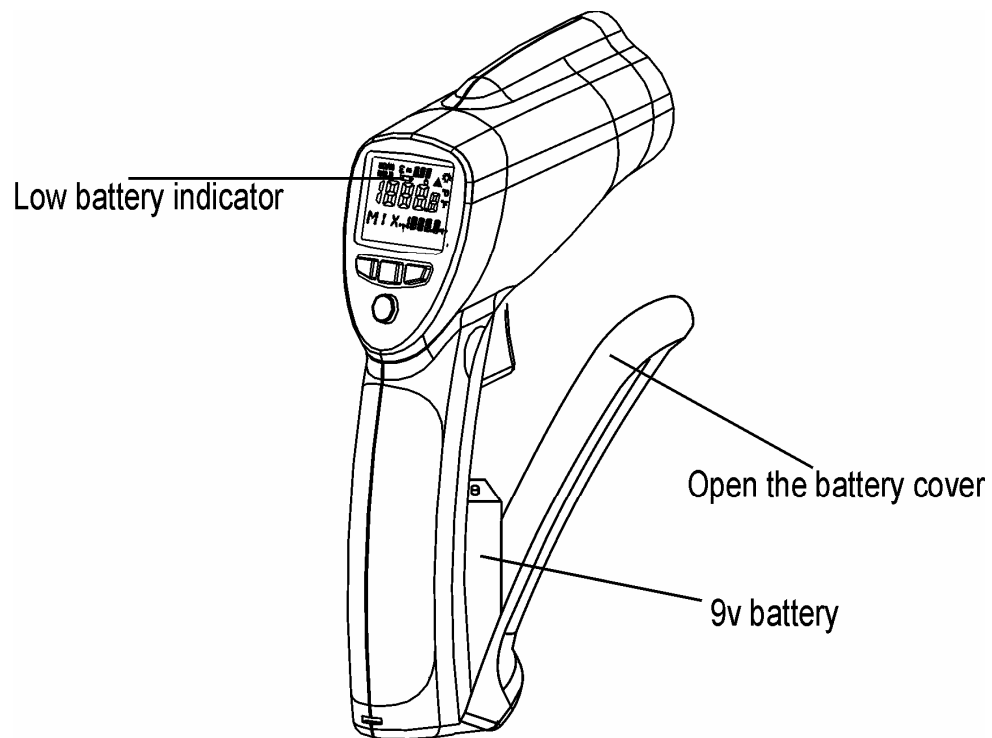

9. NOTES:

- **How it Works**

Infrared thermometers measure the surface temperature of an object. The unit's optics sense emitted, reflected, and transmitted energy, which is collected and focused onto a detector. The unit's electronics translate the information into a temperature reading, which is displayed on the unit. In units with a laser, the laser is used for aiming purposes only.

- **Field of View**

Make sure that the target is larger than the unit's spot size. The smaller the target, the closer you should be to it. When accuracy is critical, make sure the target is at least twice as large as the spot size.

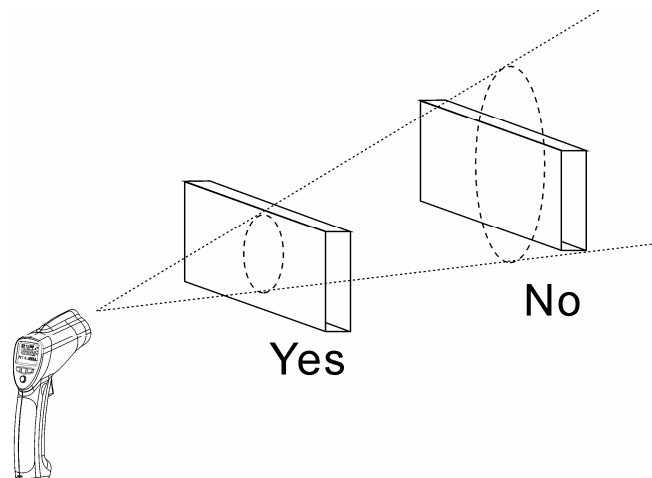

- **Distance & Spot Size**

As the distance (D) from the object increases, the spot size (S) of the area measured by the unit becomes larger. See: **Fig: 1**.

- **Locating a hot Spot**

To find a hot spot aim the thermometer outside the area of interest, then scan across with an up and down motion until you locate hot spot.

- **Reminders**

- ① Not recommended for use in measuring shiny or polished metal surfaces (stainless steel, aluminum, etc.).See **Emissivity**
- ② The unit cannot measure through transparent surfaces such as glass. It will measure the surface temperature of the glass instead.
- ③ Steam, dust, smoke, etc., Can prevent accurate measurement by obstructing the unit's optics.

- **Emissivity**

Emissivity is a term used to describe the energy-emitting characteristics of materials.

Most (90% of typical applications) organic materials and painted or oxidized surfaces have an emissivity of 0.95 (pre-set in the unit). Inaccurate readings will result from measuring shiny or polished metal surfaces. To compensate, cover the surface to be measured with masking tape or flat black paint. Allow time for the tape to reach the same temperature as the material underneath it. Measure the temperature of the tape or painted surface.

Emissivity Values

Substance	Thermal emissivity	Substance	Thermal emissivity
Asphalt	0.90 to 0.98	Cloth (black)	0.98
Concrete	0.94	Human skin	0.98
Cement	0.96	Lather	0.75 to 0.80
Sand	0.90	Charcoal (powder)	0.96
Earth	0.92 to 0.96	Lacquer	0.80 to 0.95
Water	0.92 to 0.96	Lacquer (matt)	0.97
Ice	0.96 to 0.98	Rubber (black)	0.94
Snow	0.83	Plastic	0.85 to 0.95
Glass	0.90 to 0.95	Timber	0.90
Ceramic	0.90 to 0.94	Paper	0.70 to 0.94
Marble	0.94	Chromium oxides	0.81
Plaster	0.80 to 0.90	Copper oxides	0.78
Mortar	0.89 to 0.91	Iron oxides	0.78 to 0.82
Brick	0.93 to 0.96	Textiles	0.90

10. MAINTENANCE & CLEARING:

- Repairs or serving aren't covered in this manual should only be performed by qualified personnel.
- Periodically wipe the case with a dry cloth. Don't use abrasives or solvents on this instrument.
- When serving, use only specified replacement parts.